

CHAPTER 4

Sensors and

Actuators

The Powertrain Control Module (PCM) is the on-board computer that receives input from various sensors to control various engine and emissions control actuators.

The PCM has various “memories” within it. These are: random access memory (RAM), keep alive memory (KAM) part of RAM, read only memory (ROM), and programmable read only memory (PROM).

RAM is lost whenever the ignition is turned off. KAM is where some data is retained after the ignition is turned off. KAM is where trouble codes are stored. It is also where odometer readings are stored.

ROM is programmed into the PCM at the factory and cannot be changed. This is where the various lookup tables are stored. All input signals that are analog must be converted to digital. This is accomplished in the circuitry of the Powertrain Control Module (PCM) through an analog to digital (A/D) converter.

PULL-UP & PULL-DOWN CIRCUITS

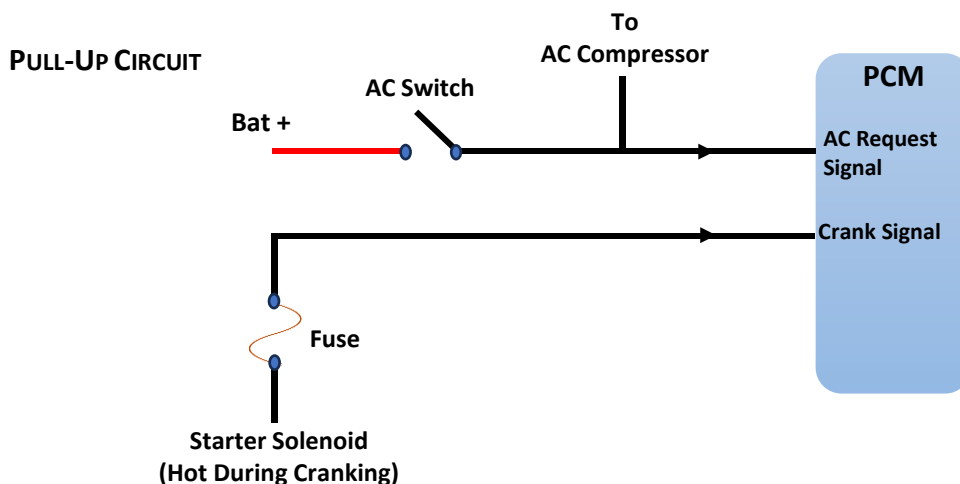

The term “pull-up circuit” is applied to a switch-controlled circuit where the PCM detects an increase in voltage when the switch is closed. In the above circuit the power is supplied by the battery. When the switch is closed, a voltage is applied to both the PCM and the A/C compressor clutch circuit. These circuits are always grounded, and the circuit is completed through the switch and the vehicle battery voltage.

Another system which uses the “pull up circuit” is the starter circuit. When the ignition switch is in the start position, the voltage is sensed by the PCM indicating the engine is being cranked. This will affect timing and air/fuel ratio.

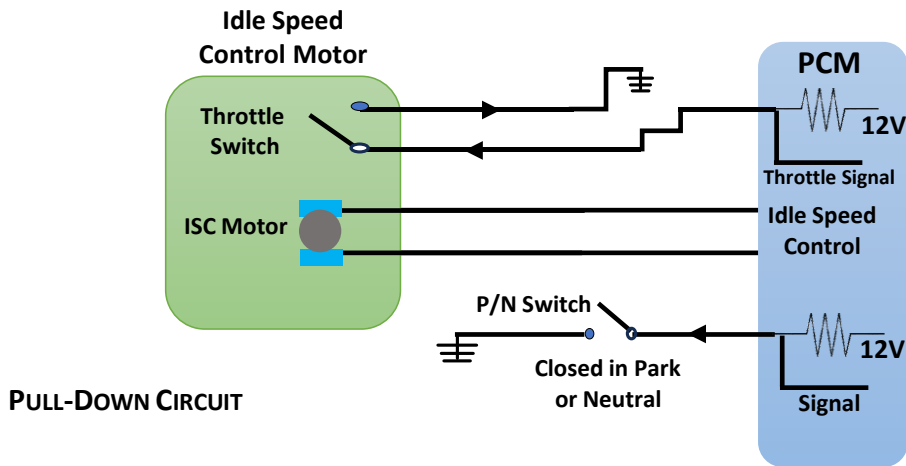

The figure shows two “pull down circuits.” These circuits differ from the “pull up circuits” in that the PCM supplies the power, and the switch completes the circuit to ground.

The first is the throttle switch-controlled circuit. The PCM supplies 12 volts to the circuit. There is a fixed resistor (non-variable) inside the PCM. When the throttle switch is closed, the 12 volts are dropped across the fixed resistor. The PCM then detects a 0-volt reading, and it determines the throttle switch is closed.

The second “pull down circuit” is the park/neutral switch. The PCM supplies the 12 volts to the circuit. When the park/neutral switch is closed the PCM senses a 0-volt reading. The PCM then determines the circuit is complete and will enable or disable the starter circuit. The PCM uses this signal for control of various systems.

ZIRCONIUM O₂ SENSORS

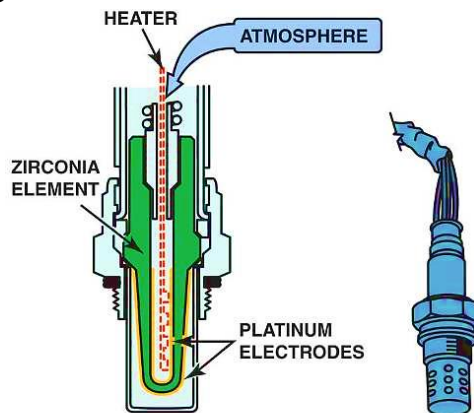

This sensor is used to detect the amount of oxygen left in the exhaust stream after the combustion process. If the mixture is too lean, there will be excess oxygen in the exhaust stream. This will generate a voltage below 0.5 volts. If the mixture is too rich there will be a lack of oxygen in the exhaust stream. This will generate a voltage above 0.5 volts.

The normal running engine will show an oscillating signal between 0.1volts and 0.9 volts. It is important to determine if the sensor is either biased or slow. Either of these conditions will affect the production of emissions and will reduce the efficiency of the catalytic converter.

To test the O₂ sensor runs the engine until reaching operating temperature. Slowly add propane to the induction system until there is a reduction in engine speed (rich mixture). With a DSO monitoring the O₂ sensor signal, remove the propane. When the trace has reached its lowest level, snap-accelerate the engine. At this point “freeze” the DSO screen. Next measure the amount of time taken to switch from a lean signal to a rich signal. This should be no more than 80m/s. Also observe the lowest and highest voltage level. The highest should be no less than 800m/v. The lowest should be no higher than 175m/v.

These sensors are one wire (grounded to the exhaust manifold), two wire (signal and sensor ground), Three wire (signal, ground, and heater) and four wire (signal, ground, and heater with ground). The main function of this sensor is to fine tune the air/fuel mixture. If the sensor is not functioning properly, emissions and driveability will be affected.

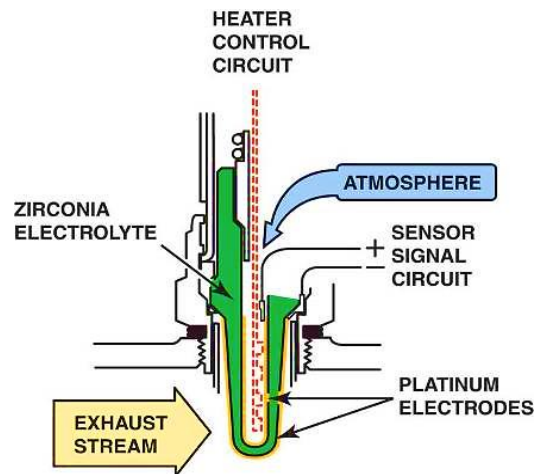

Above is the schematic for a four-wire zirconium oxygen sensor. It should be noted that the signal wire is shown as a shielded wire. This is true of some sensors but not all. The technician should note the metallic ground used on this sensor. In some cases, the manifold is used as the sensor ground. The reason for the metallic ground is to provide a “cleaner” signal to the PCM. If the sensor uses the manifold as a ground, voltage spikes will be picked up by the signal from the voltage “noise” in the ground return to the battery.

The PCM uses a comparator circuit to determine the actual voltage signal being generated by the sensor. The heater for the sensor also uses metal ground. This prevents any “noise” being generated to the sensor signal.

The only true test of these sensors is the digital storage oscilloscope (DSO) or by understanding and accessing Mode 6. A DMM is not apt to test the sensors' bias or reaction time.

TITANIA O₂ SENSORS

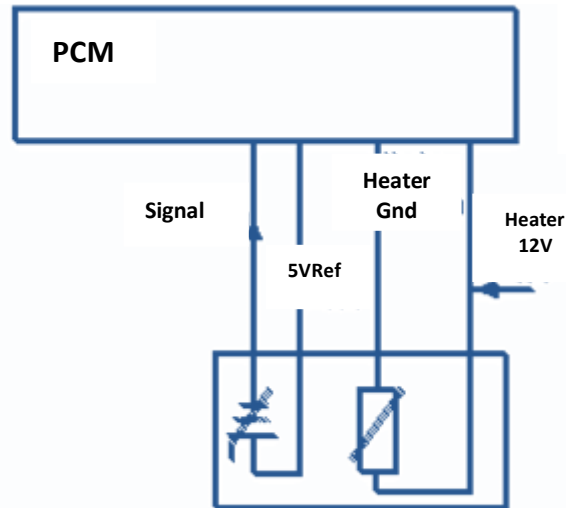

The Titania oxygen sensor operates differently than the Zirconium oxygen sensor. The Titania sensor must have a reference voltage applied to function. The first described is used on Jeep vehicles. It requires a 5-volt reference supplied by the PCM. The signal is taken before the variable resistor which completes the circuit to ground. As the variable resistor increases in resistance, the signal voltage increases. This is because when the resistance increases the amperage decreases. With this decrease in amperage, the voltage drop across the fixed resistor in the PCM will be less, and the signal voltage will increase. When the mixture is lean the variable resistance increases. The signal voltage will then increase. The reverse is also true, when the mixture is rich (low O₂) the variable resistance decreases with a decrease in signal voltage. Rich mixture=low signal voltage, Lean mixture=high signal voltage.

The second type of Titania sensor is used on some Nissans and Toyotas. It uses a 1-volt reference. The signal is taken after the variable resistor and before the fixed resistor. The result is an opposite reading for the same O₂ content in the exhaust. With a high O₂ content the variable resistor increases in resistance. The voltage drop across this resistor is higher and less voltage is available to the signal voltage line. Lean mixture=low signal voltage. Rich mixture=high signal voltage.

WIDE BAND AIR FUEL (AF) O₂ SENSORS

Honda was the first manufacturer to use wide band oxygen sensors beginning in 1992. Wide-band oxygen sensors are used by most vehicle manufacturers to ensure that the exhaust emissions can meet the current standard.

A wide-band oxygen sensor is capable of supplying air–fuel ratio information to the PCM over a much broader range. The use of a wide-band oxygen sensor compared with a conventional zirconia oxygen sensor differs as follows:

- Able to detect exhaust air–fuel ratio from as rich as 10:1 and as lean as 23:1 in some cases.
- Cold-start activity within as little as 10 seconds.

In a conventional zirconia oxygen sensor, a bias or **reference voltage** can be applied to the two platinum electrodes, and then oxygen ions can be forced (pumped) from the ambient reference air side to the exhaust side of the sensor. If the polarity is reversed, the oxygen ion can be forced to travel in the opposite direction.

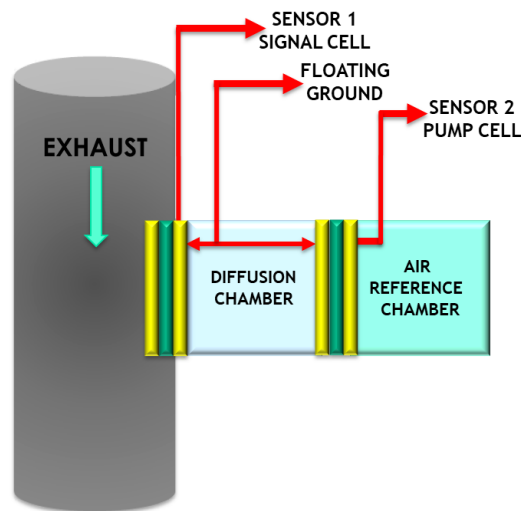

A planar-type wide-band oxygen sensor is made like a conventional planar O₂S and is labeled *Nernst cell*. Above the Nernst cell is another zirconia layer with two electrodes, which is called the *Pump cell*. The two cells share a common ground, which is called the reference. There are two internal chambers:

- The *Air Reference Chamber* is exposed to ambient air.
- The *Diffusion Chamber* is exposed to exhaust gases.

Platinum electrodes are on both sides of the zirconia electrolyte elements, which separate the air reference chamber and the exhaust-exposed diffusion chamber. The basic principle of operation of a typical wide-band O₂ sensor is that it uses a positive or negative current signal to keep a balance between two sensors. Oxygen (O₂) sensors do not measure the quantity of free oxygen in the exhaust. Instead, O₂ sensors produce a voltage that is based on the ion flow between the platinum electrodes of the sensor to maintain the stoichiometric balance.

If the exhaust is lean, there is more oxygen in the exhaust and the ion flow from the ambient side to the exhaust side is low. If the exhaust is rich, the ion flow is increased to help maintain balance between the ambient air side and the exhaust side of the sensor.

The PCM can apply a small current to the Pump Cell electrodes, which causes oxygen ions to move through the zirconia into or out of the diffusion chamber. The PCM pumps O_2 ions in and out of the diffusion chamber to bring the voltage back to 0.450, using the pump cell.

The operation of a wide-band oxygen sensor is best described by looking at what occurs when the exhaust is stoichiometric, rich, and lean. When the exhaust is at stoichiometric (14.7:1 air–fuel ratio), the voltage of the Nernst cell is 450 mV (0.450 V). The voltage between the diffusion chamber and the air reference chamber changes from 0.450 V. This voltage will be:

- Higher if the exhaust is rich
- Lower if the exhaust is lean

The two sensors share a common (floating) ground. The sensor in contact with the exhaust is referred to as the “Sense” Signal Cell, or *Sensor 1*. The sensor in contact with the Diffusion Chamber and the Air Reference Chamber is referred to as the “Pump” Ion Cell, or *Sensor 2*.

System Operation

- Sensor #1 operates as a traditional O_2S , sending a high volt signal (above 450mV) to the PCM when the A/F ratio is rich (low O_2), and a low volt signal (below 450 mV) when the A/F ratio is lean (high O_2).
- The purpose of the Diffusion Chamber and Sensor #2 is to counteract the changing voltage of Sensor #1 and keep it at 450mV (stoichiometry).
- To keep Sensor 1 at 450 mV, requires that Sensor 2 provides a current flow that will move the O_2 ions in the opposite direction than Sensor 1 has them moving relative to exhaust O_2 content.

For example, if a rich mixture enters the exhaust stream (low O_2), many O_2 ions will flow from the Diffusion Chamber, through Sensor 1. The voltage on Sensor 1 will move toward 450mV. When Sensor 1 voltage rises above 450mV (rich mixture), the PCM reacts by providing a negative current flow on Sensor 2 to pump O_2 towards the Diffusion Chamber and Sensor 1. This action brings Sensor 1 voltage back to the target 450mV.

When the O_2 content in the exhaust is high (lean mixture – low O_2 ion transfer), the system reacts in the opposite manner. Sensor 1 sends a low voltage signal (under 450 mV) to the PCM. The PCM sends a positive (+) amp signal to Sensor 2, to increase O_2 ion transfer through Sensor 1. This action brings the voltage up to 450mV. As you can see, Sensor 2 controls Sensor 1’s voltage, by applying a positive or negative current flow. The PCM monitors the current flow change on Sensor 2 and makes fuel and timing corrections based on those changes.

If there is zero current flow on Sensor 2, the air/fuel ratio is at equilibrium (14.7:1)

Most service information specifies that a scan tool be used to check the wide-band oxygen sensor. This is because the PCM performs tests of the unit and can identify faults which it then stores in Mode 6. However, even wide-band oxygen sensors can be fooled if there is an exhaust manifold leak or other fault which could lead to false or inaccurate readings. If the oxygen sensor reading is false, the PCM will command an incorrect amount of fuel.

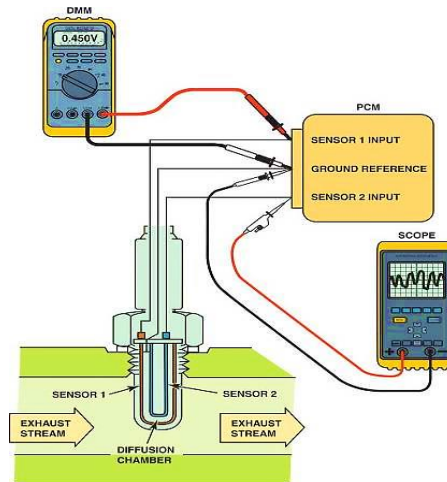

Testing

When testing a wide-band oxygen sensor for proper operation, perform the following steps:

- **STEP 1** Check service information and determine the circuit and connector terminal identification.
- **STEP 2** Measure the calibration resistor. While the value of this resistor can vary widely, depending on the type of sensor, the calibrating resistor should still be checked for opens and shorts.
- **STEP 3** Measure the heater circuit for proper resistance or current flow.
- **STEP 4** Measure the reference voltage relative to ground. This can vary but is generally 2.4 to 2.6 volts.
- **STEP 5** Using jumper wires, connect an ammeter and measure the current in the pump cell control wire.

Testing a dual cell wideband oxygen sensor can be done using a voltmeter or a scope. The meter reading is attached to the Nernst cell and should always read stoichiometric (450 mV). The scope shows activity to the pump cell with commands from the PCM to keep the Nernst cell at 14.7:1 air–fuel ratio.

THROTTLE POSITION SENSORS (TPS)

Most throttle position sensors are potentiometers. This type of sensor converts a variable voltage signal into a percentage of throttle opening. The PCM uses this signal to determine fuel delivery, spark timing and transmission shifting. The TPS is usually a three-wire sensor. One wire supplies reference voltage, the second wire conducts the signal to the PCM, and the third wire is the sensor ground.

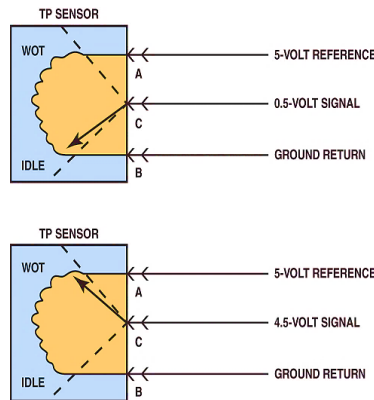

As the wiper moves across the resistor, the signal voltage changes to reflect the throttle angle. The PCM uses this information along with the RPM signal to help determine the proper air/fuel ratio and ignition timing.

If the PCM sees a signal voltage of 80% throttle opening, it considers the throttle to be in the “wide open” position. If the PCM sees this type of signal from the TPS during cranking, the system would go into “clear flood” mode, and the result would be a “no start” condition. This causes no injector pulse. If the signal from the TPS “drops out” while the wiper is moved across the resistor, the result will be hesitation. The reason for this is the PCM interprets this drop out as a deceleration signal and will stop the injectors.

The best tool to diagnose the TPS is a DSO. With the scope hooked up to the signal wire and ground, the TPS should be opened to WOT and allowed to return to an idle position.

The trace on the scope should be a smooth transition from a low voltage signal to a high voltage signal and a smooth return to a low voltage signal.

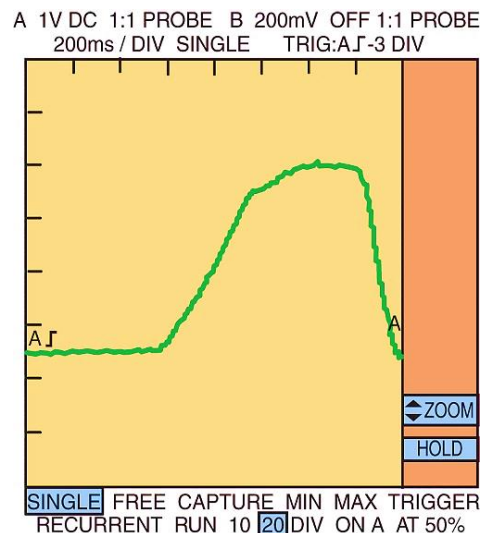

TEMPERATURE SENSORS

Temperature sensors are also known as *Thermistors*. It means that as the temperature changes the voltage signal changes. Most temperature sensors are negative temperature coefficient (NTC) thermistors. This means that as the temperature of the sensor increases, the electrical resistance decreases. There are also positive temperature coefficient (PTC) thermistors, which increase in electrical resistance as the temperature of the sensor increases.

A reference voltage is applied through a fixed resistor in the PCM. As the resistance of the sensor changes, the amperage in the circuit changes. With the change in amperage, the amount of voltage drop across the fixed resistor changes. The PCM measures the voltage available after the fixed resistor.

On an NTC thermistor if the amperage increases (lower resistance in the sensor) the voltage drop across the fixed resistor increases. The result would be a lower available voltage sensed by the PCM. This would be interpreted by the PCM as a higher temperature.

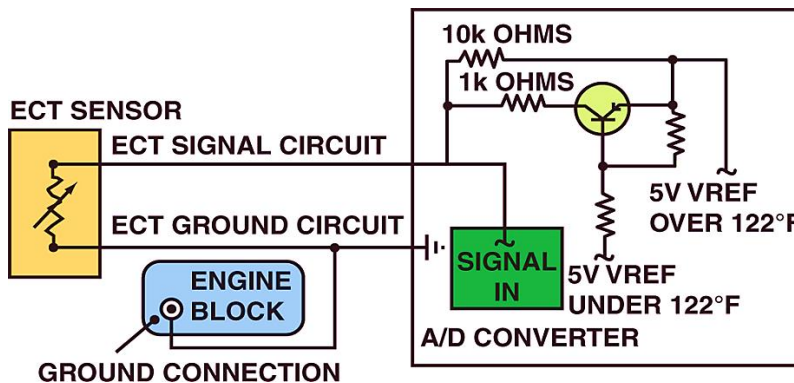

The figure above shows a stepped engine coolant temperature sensor circuit. The purpose of this extra circuit is to give the PCM a more accurate reading of the engine coolant temperature compared to the same sensor with only one circuit.

When the voltage drop reaches approx 1.20V, the PCM turns on a transistor. The transistor connects a 1k Ω resistor in parallel with the 10k Ω resistor. Total circuit resistance now drops to approx 909 ohms. This function allows the PCM to have full binary control at cold temperatures up to approx 122°F, and a second full binary control at temperatures greater than 122°F.

The transition between steps usually occurs at a temperature that would not interfere with cold engine starts or the cooling fan operation. In this example, the transition occurs when the sensor voltage is about 1 volt and rises to about 3.6 volts.

MANIFOLD ABSOLUTE PRESSURE (MAP) SENSOR

The internal combustion engine is basically an air pump. As the piston moves down on the intake stroke, the intake valve opens. This downward movement of the piston creates a low-pressure area and opens the large area in the cylinder for air to fill. Low-pressure in the cylinder is what we know as “**vacuum**.” Vacuum draws air into the cylinder.

As an engine is accelerated under a load, the vacuum drops. This drop is an increase in pressure in the intake manifold. A MAP sensor senses all pressures greater than that of a perfect vacuum.

The MAP sensor is used by Powertrain Control Module (PCM) to sense engine load. Typical MAP sensors consist of ceramic or silicon wafers sealed on one side with vacuum and exposed to intake manifold vacuum on the other side. As engine vacuum changes, pressure difference on the wafer or silicon chip changes the output voltage or frequency of the MAP sensor.

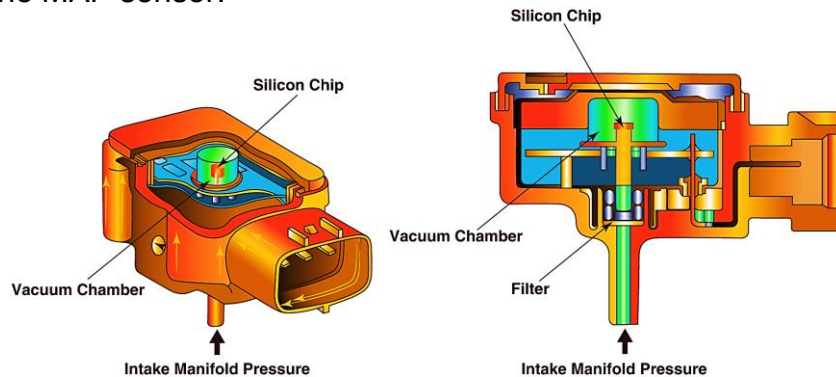

A MAP sensor compares the absolute pressure in the intake manifold to a perfect vacuum. The deflection of the silicon chip is converted to an absolute pressure reading by the electronics in the sensor.

The relationship among barometer pressure, engine vacuum, and MAP sensor voltage includes:

- Absolute pressure is equal to barometric pressure minus intake manifold vacuum.
- MAP sensor compares manifold vacuum to perfect vacuum.
- Barometric pressure minus MAP sensor reading equals intake manifold vacuum.
- Supercharged and turbocharged engines require MAP sensor calibrated for pressures above atmospheric as well as for vacuum.

When checking a MAP sensor, first verify that the sensor is receiving a 5-volt reference voltage and then check for the output (signal) voltage. Monitor injector pulse width in milliseconds when vacuum is applied to MAP sensor.

Step 1: Apply 20 in. Hg of vacuum to MAP sensor.

- Start engine

Step 2: Observe injector pulse width.

- On warm engine, injector pulse width will be 1.5 to 3.5 ms

Step 3: Slowly reduce vacuum to MAP sensor.

- Observe injector pulse width
- Lower vacuum to MAP sensor indicates heavier load on engine
- Injector pulse width should increase

MAP Sensor Circuit

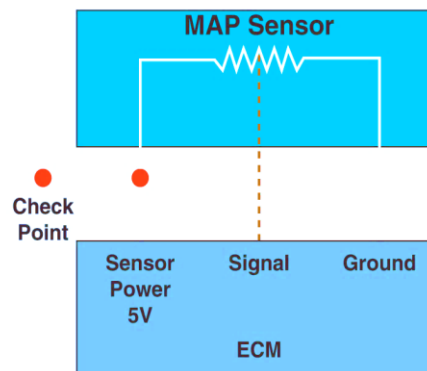

BAROMETRIC PRESSURE (BARO) SENSOR

Barometric pressure (BARO) sensor senses subtle changes in barometric absolute pressure. A Barometric manifold absolute pressure (BMAP) is combination of a BARO and MAP sensor in same housing. A BMAP sensor has individual circuits to measure barometric and manifold pressure. The BARO is an input that determines altitude, allowing the PCM to adjust to changes in atmospheric pressure.

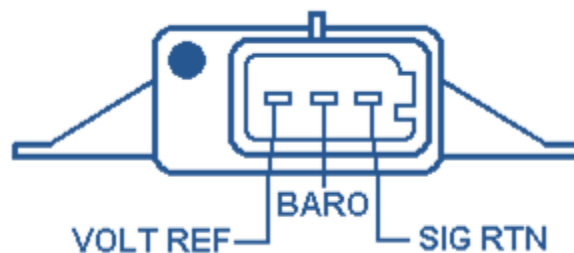

A MAP sensor and a BARO sensor are usually the same sensor, but the MAP sensor is connected to the manifold and a BARO sensor is open to the atmosphere. The MAP sensor can read barometric pressure just as the ignition switch is turned On and before the engine starts. Therefore, altitude and weather changes are available to the PCM.

On speed-density systems, the MAP sensor will take a reading of the barometric pressure as the engine is started. This reading is usually stored by the PCM until the key is turned off. When testing an intermittent problem try lightly tapping on the sensor and listen for engine change.

Testing BARO Sensor Signal- Attach the positive lead of a DVOM or lab-scope to the signal wire. The voltage or frequency should change in relation to the pressure as vacuum is applied to the sensor. Check reference material for specs on voltage or frequency reading at a given pressure.

MASS AIRFLOW (MAF) SENSOR

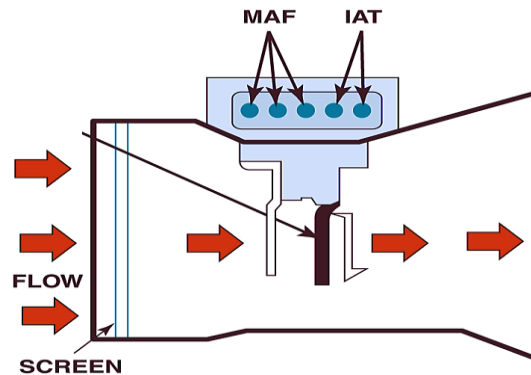

Mass Airflow (MAF) sensors convert intake airflow information into an electrical signal. This information is used by the PCM for fuel delivery and spark timing. MAF sensors will generate either a digital or an analog signal depending on the type.

Modern MAF sensors use a hot wire or a heated film element to measure intake airflow. As the airflow passes through the heated film or wire, the element is cooled. This cooling changes the resistance and current flow output of the sensor. Electronics in the sensor increase the current flow through the hot film or wire to maintain the 70°C temperature differential between air temperature and temperature of the hot film or wire. The change in current flow is converted to a frequency output that the PCM uses to measure airflow.

Most MAF sensors incorporate a built-in Intake Air Temperature (IAT) sensor. Hot wire MAF sensors also incorporate a burn-off circuit. Burn-off is turned on when the ignition switch is turned off, after the engine has been operating at normal operating temperature. This circuit heats up the hot wire for a few seconds to burn off any contaminants.

The PCM uses information from the MAF sensor for the following purposes:

- To determine the amount of fuel needed and base pulse-width numbers.
- The greater the mass of incoming air, the longer the injectors are pulsed, and timing is retarded.
- MAF measures air density and can continuously calculate BARO.
- Backs-up the TPS in the event of a loss of signal or an inaccurate TPS signal.

Tip: *When MAF is dirty, BARO will be out of calibration.*

MAF Sensor Output Test

MAF sensors calculate air mass, by weight, in a given amount of time. A digital multimeter (DMM), set to read DC volts on the signal wire, can be used to check the MAF sensor signal. Typical normal airflow at idle is 3 to 7 grams per second. Always check manufacturer's procedures and specifications when testing MAF sensors.

Dirt, oil, silicon, and other debris can coat the sensing element. At engine idle, a contaminated sensor can overestimate the amount of air entering engine. At higher speeds, near WOT, contamination can cause the sensor to underestimate the amount of air entering the engine. To check for contamination, check fuel trim numbers and perform a volumetric efficiency test.

The Unplug It Test

If a sensor is defective yet still produces a signal to the PCM, the PCM will accept the reading and make the required changes in fuel delivery and spark advance. If, however, the sensor is not reading correctly, the PCM will process this wrong information and perform an action assuming the information being supplied is accurate.

For example, if a MAF sensor is sending a signal equivalent to 12 grams of air per second going into the engine, the PCM will pulse the injectors for a longer amount of time than it is programmed to do. However, if the air going into the engine is 14 grams per second, the amount of fuel supplied by the injectors will not be enough for proper engine operation.

If the MAF sensor is unplugged, the PCM knows that the sensor is not capable of supplying airflow information, so it defaults to a fixed amount of fuel based on the values of other sensors such as the TPS and MAP sensors. *"If in doubt, take it out."* If the engine operates better with the sensor unplugged, then suspect that the sensor is defective. A sensor that is not supplying the correct information is said to be *"skewed."*

CRANKSHAFT POSITION (CKP) SENSOR

The device that signals the switching of the coil on and off is called the trigger (typically a pickup coil in some distributor-type ignitions and a crankshaft position sensor (CKP) on electronic systems)

To get a spark out of the ignition coil, the primary coil circuit must be turned on and off. The primary circuit current switching is controlled by a transistor inside the ignition module or igniter by one of the following devices:

- **Hall-Effect Switch**

- A Hall-effect sensor produces an on-off voltage signal whether it is used with a blade or a notched wheel.
- Some Hall-effect sensors look like magnetic sensors.
- A Hall-effect sensor produces an ON-OFF DIGITAL voltage signal
- Hall-effect crankshaft position sensors create a 0 to 5V signal.

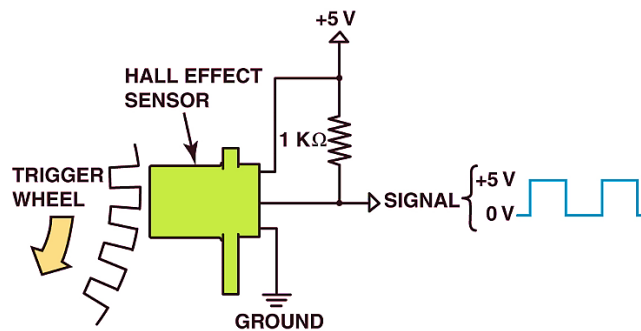

- **Magnetic sensor**

The ICM receives voltage from the pickup coil and opens the ground circuit to the ignition coil when the voltage starts down from its peak (just as the reluctor teeth start moving away from the pickup coil).

- A magnetic sensor uses a permanent magnet surrounded by a coil of wire. The notches of the crankshaft (or camshaft) create a variable magnetic field strength around the coil.
- When a metallic section is close to the sensor, the magnetic field is stronger because metal is a better conductor of magnetic lines of force than air.
- A magnetic sensor uses a permanent magnet surrounded by a coil of wire. The notches of the crankshaft (or camshaft) create a variable magnetic field around the coil. When the wheel notch is close to the sensor, the magnetic field is interrupted.
- A Magnetic Type Pickup Sensor produces a *sine wave analog* signal.

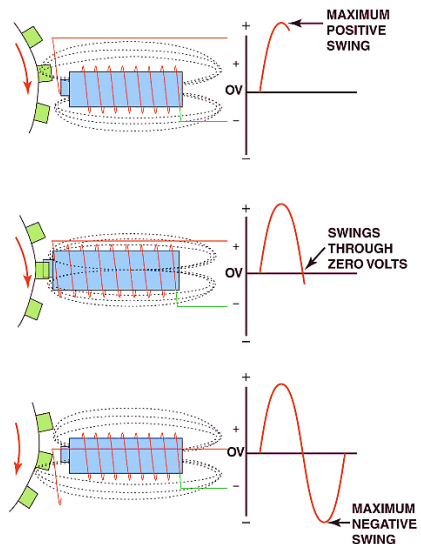

LIGHT-EMITTING DIODES (LED)

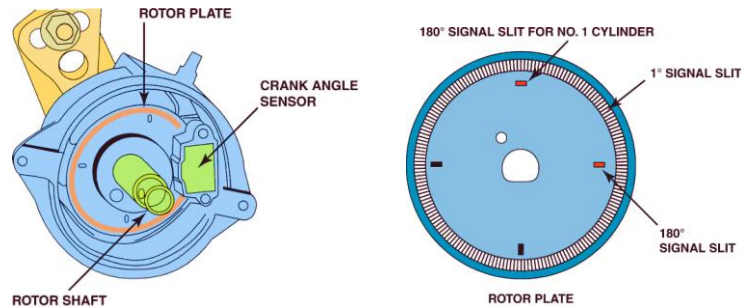

Crank/RPM sensors convert engine RPM into a voltage signal which the PCM uses for RPM, ignition timing, injector timing and over rev control. RPM sensors are also used to trigger the module when controlling the primary ignition.

Some distributors incorporate Optical (LED) sensing devices to give cylinder ID and RPM signals. Inside the distributor is a thin disk which usually has two rings of small slots cut into it. The outer ring has 360 slots (one for every degree of rotation), and the inner ring of slots has one for each cylinder. Some systems will have a wider slot for number one cylinder to show engine position.

These systems use Light Emitting Diodes (LED) on one side of the disk and a Photo Transistor on the other side. As the light reaches the photo transistor, a signal is produced and sent to the ignition module or the PCM. These distributors usually have 4 wires, system voltage, ground, and one wire for each signal.

A Digital Storage Oscilloscope (DSO) is recommended to test this sensor signal. The signal should be a DC digital square wave. Follow manufacturer's procedures for the specific system to be tested.

EXHAUST GAS RECIRCULATION (EGR) SENSORS

The EGR valve sensor changes the valve pintle movement or exhaust flow into a voltage signal, which the PCM uses for fuel delivery and spark timing calculations. EGR valve position sensors are usually three-wire potentiometers with a reference voltage, a ground, and a signal wire.

Current flows from the reference through the resistor in the sensor and on to ground. As the voltage drops through the resistor, a wiper (moved by the EGR pintle) senses the voltage at that point. That signal is sent to the PCM by the sensor wire. On some systems a low voltage signal (0.5 to 1.3v) will indicate a closed EGR valve.

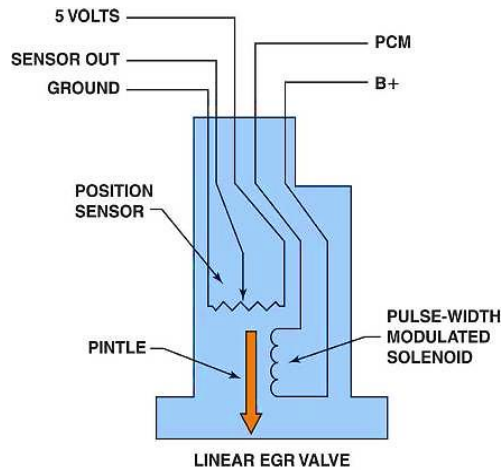

Some manufacturers use thermistors to monitor EGR flow by looking at the temperature of the gases flowing through the EGR valve. If a thermistor is used, test it the same way as you would test a coolant temperature sensor circuit. A thermistor will open or close the circuit depending on the temperature.

Some systems monitor MAP and Fuel Trim while operating the EGR valve. This allows the PCM to see the effect on engine operation. Newer systems use the variable valve timing system (VVT), to introduce EGR into the cylinders.

The VVT system uses electronically controlled, hydraulic gear-driven cam phasers that can alter the relationship of the camshaft from 15 degrees retard to 25 degrees advance (40 degrees overall) relative to the crankshaft. Variable valve timing (VVT) allowed engineers to eliminate the EGR valve and still be able to meet the standards for oxides of nitrogen (NO_x). Using the exhaust cam phasing, the PCM can close the exhaust valves sooner than usual, thereby trapping some exhaust gases in the combustion chamber. General Motors uses one or two actuators that allow the camshaft piston to change by up to 50 degrees in relation to the crankshaft position. The VVT system also works in conjunction with an active manifold that gives the engine a broader torque curve.

KNOCK SENSORS

Knock sensors convert engine pinging (or vibration) into a voltage signal. The PCM uses this information to retard the spark timing to try to control the spark knock. It is possible for the sensor to pick up engine or component noise, which can retard ignition timing erroneously.

Most knock sensors are piezoelectric type sensors. They have a piezoelectric crystal that generates an A/C signal with a frequency and voltage proportional to the engine vibration it senses. They are mostly a one-wire sensor where the circuit is completed (grounded) through the mounting of the sensor. In some cases, the knock signal will be sent to an Electronic Spark Control (ESC) module to be processed before being sent to the PCM.

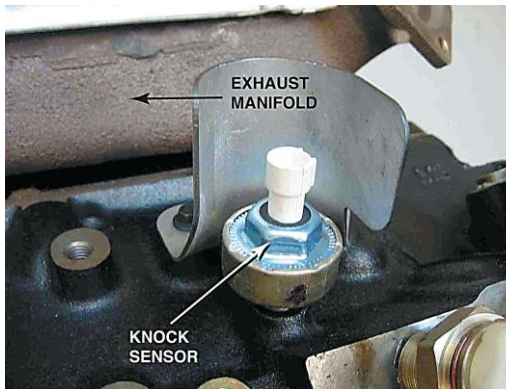

A 50V AC 1:1 PROBE B 200mV OFF 1:1 PROBE
500µS / DIV SINGLE TRIG:AJ-2DIV

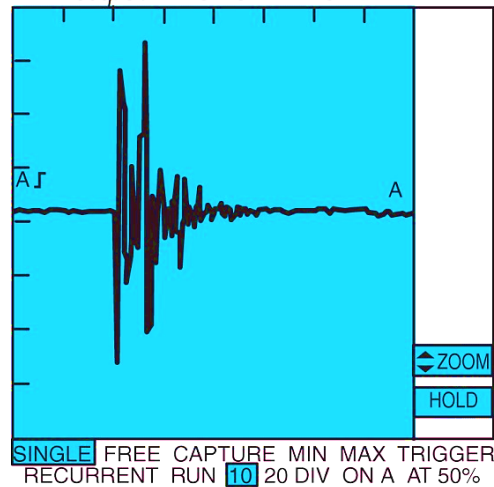

Most knock sensors use a shielded signal wire to eliminate magnetic interference from inducing a voltage on the signal line. If the shielded wire is damaged or the wire is routed too close to a magnetic field (like ignition coils), it may result in a false knock signal. Some systems will send a bias voltage to the sensor. The AC signal generated by the sensor will then vary the bias voltage. Other systems use a piezoresistive type sensor which changes resistance to vary a reference voltage. The knock sensor is tuned to the engine knock frequency, in a range from 5 to 10 kHz depending on the engine design.

- **Diagnosing the Knock Sensor**

A scan tool can be used to check the operation of the knock sensor, using the following procedure:

- **STEP 1:** Start the engine and connect a scan tool to monitor ignition timing and/or knock sensor activity.
- **STEP 2:** Create a simulated engine knocking sound by tapping on the engine block or cylinder head with a soft faced mallet or small ball peen hammer.
- **STEP 3:** Observe the scan tool display. The vibration from the tapping should have been interpreted by the knock sensor as a knock, resulting in a knock sensor signal and a reduction in the spark advance.

Some PCMs are programmed to ignore knock sensor signals when the engine is at idle speed, to avoid having the noise from a loose accessory drive belt or other accessory interpreted as engine knock. Always follow the vehicle manufacturer’s recommended testing procedure.

VEHICLE SPEED (VSS) SENSORS

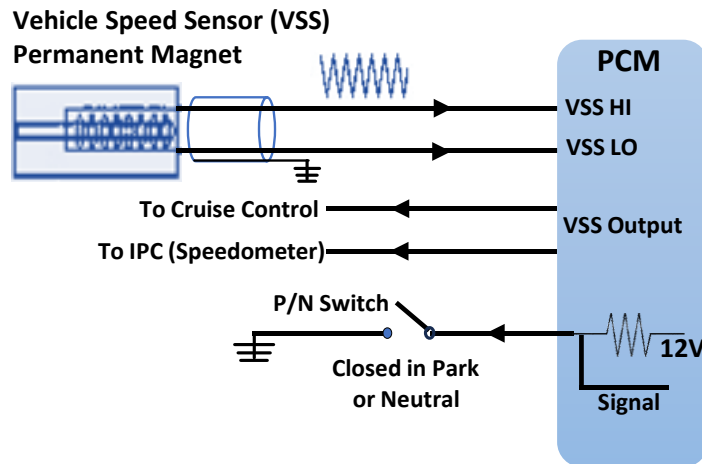

Vehicle speed sensors convert vehicle speed into a digital or analog signal that is sent to the PCM. This information can be used by the PCM for transmission shifting, cruise control, and over-speed control. Vehicle speed sensors can be a Permanent Magnet Generator, or a Hall Effect switch.

Some vehicle speed sensors are mounted in the transmission and run out of the output shaft. Sometimes the VSS signal is routed through an analog to digital (AD) converter before it is sent to the PCM. VSS signals are also used for electronic speedometers. Most of these circuits also have shielded leads to eliminate interference. The PM generator produces an AC voltage while the Hall Effect and reed switches give a digital signal.

Refer to reference material for specs. When testing the signal from Hall or reed switches, use a DVOM or lab-scope. On a reed switch, the voltage drop across the switch should not exceed 0.2 volts.

ELECTRONIC FUEL INJECTOR

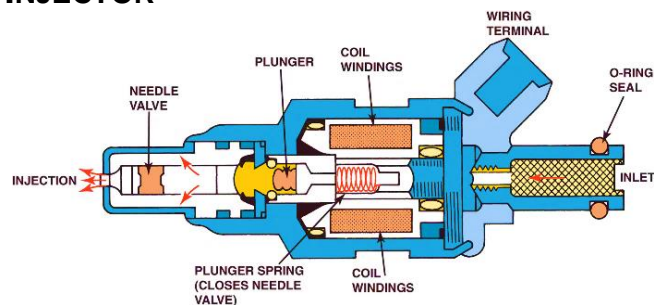

Fuel injectors are a Solenoid used to deliver fuel and are pulsed on to control the air fuel mixture. Injectors are usually energized for 3 to 10 milliseconds. An injector on time of more than 5 ms usually indicates a rich command.

The injector has two wires, one supplies system voltage (key on) to the injector. The PCM completes the circuit (ground) through the other wire via the PCM. The PCM completes the circuit to energize the solenoid. When the solenoid is energized fuel flows through the injector. The PCM can increase or decrease the "on-time" of the injector to control the air fuel mixture.

The PCM needs an RPM signal before it will pulse the fuel injectors. Some systems will use two injector driver circuits to handle more current in each circuit. The more injectors in a parallel circuit, the more current flows through the drivers.

Some systems use one driver to pull the injector on and one driver to hold the injector on. This is generally called a current-limiting injector circuit.

Testing the Injector

- Resistance. Attach the leads of a DVOM to test the resistance of the injector windings as shown on the figure. Check your reference materials for specs on the injector resistance.
- Testing Feed Circuit. Attach the positive lead of a DVOM or lab-scope to the feed wire. Check for system voltage supplied to the injector.
- Testing Ground Circuit. The circuit is only grounded when the PCM wants the injector to be energized. Attach a lab-scope to the ground side of the injector. As the PCM grounds the circuit, the voltage should be close to 0V.

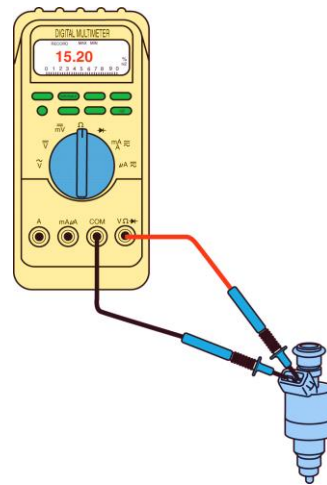

IDLE SPEED CONTROL

There are three basic types of idle speed controls, DC motor, stepper-motor and solenoid. The systems using a DC motor will reverse the polarity (current flow) through the motor to position the plunger. Two wires are generally used on these motors. Generally, these systems will not control the idle speed until a switch indicates that the throttle is closed. On the stepper-motor systems, the stepper motor has two separate windings in the motor. The PCM will energize each winding separately and will reverse the polarity to control the position of the plunger. These systems have four wires attached to the motor, two for each winding (circuit).

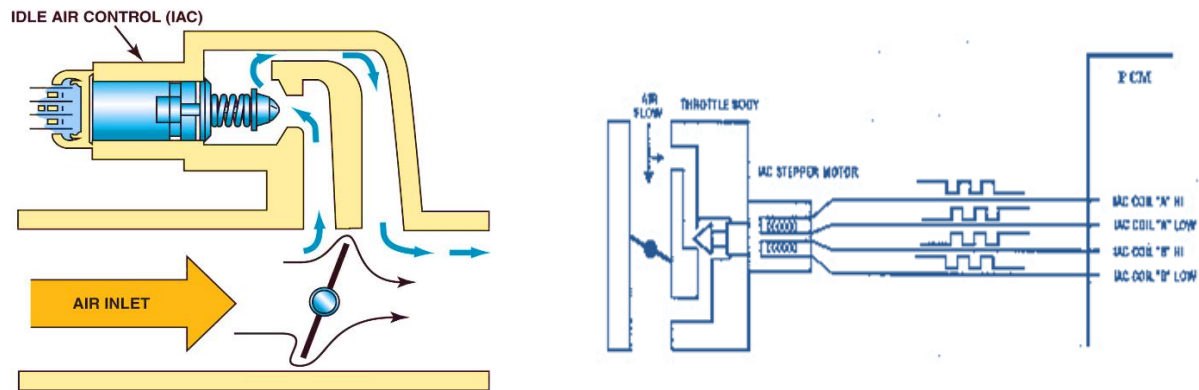

On the type of idle control that uses a solenoid, the solenoid opens and closes an orifice in the throttle intake. The PCM controls the ground circuit of the solenoid via pulse width modulation. On many Ford systems, the ECM pulses the solenoid continually to control the idle speed. They vary the voltage more than the frequency which controls the current flowing through the solenoid. This means that the solenoid is held open (part way), depending on the current flow. Many systems use changes in ignition timing to make small changes in idle speed. The idle speed control motor may not be activated until the PCM needs at least a 50 RPM change.

- Testing the Solenoid or Motor -Use a DVOM to test the resistance of the solenoid or the stepper-motor windings. Check your reference material for specs.
- Testing Feed Circuit -Use a DVOM or a lab-scope to check for system voltage supplied to the solenoid or motor. In some cases, the circuit will be powered up only when the PCM energizes the motor.
- Testing Ground Circuit -The circuit is only grounded when the PCM energizes the solenoid. Use a lab-scope on solenoid and Stepper motors systems. The voltage should be close to 0 when the system is grounded.

ELECTRONIC THROTTLE CONTROL (ETC) SYSTEMS

Electronic Throttle Control (ETC) systems eliminate mechanical throttle cables, reducing the number of moving parts. The system also eliminates the need for cruise control actuators and controllers, and idle air control valves or solenoids. ETC systems can also reduce engine power for traction control and electronic stability control systems and delay rapid applications of torque to transmission/transaxle to help improve driveability and to smooth shifts.

ETC systems use two, sometimes three, Accelerator Pedal Position (APP) Sensors. These sensors act together to give accurate pedal position information to the controller, and to verify the other sensor(s) are working properly. APP sensors function just like a Throttle Position Sensor (TPS). Using two or three signals improves redundancy should one sensor fail and allows the PCM to quickly detect a malfunction.

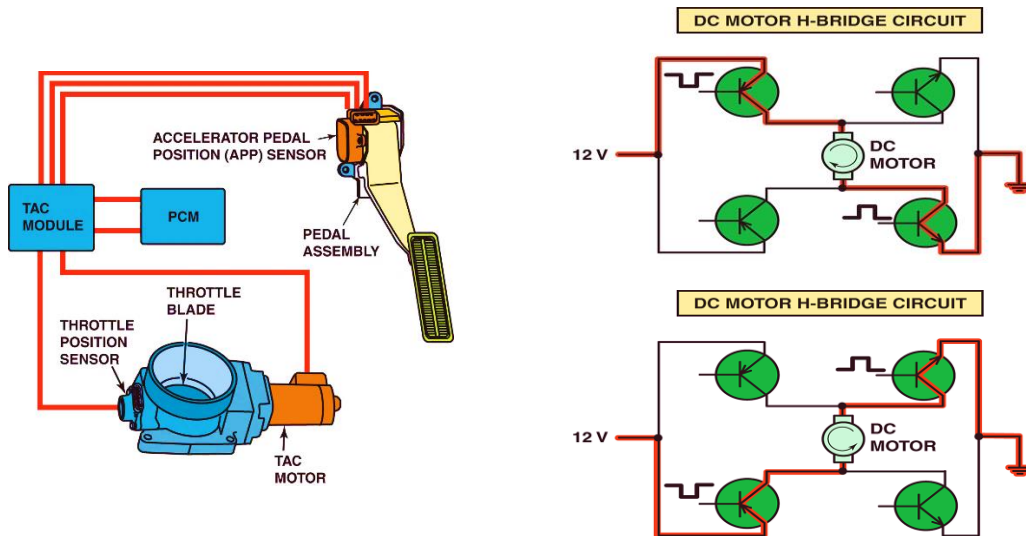

The Electronic Throttle Body motor actuator is a DC electric servomotor. The throttle plate is held in default position by a spring inside the assembly. The Neutral (fail safe) position represents approximately 16-20% throttle opening, which usually results in engine speeds of 1200-1500 RPM. The controller then drives the throttle plate closed or open to achieve idle speeds or speeds higher than idle (acceleration).

An H-bridge circuit is used to control the direction of the DC electric motor in the electronic throttle control unit. To reverse the direction of operation, the polarity of the current through the motor is reversed.

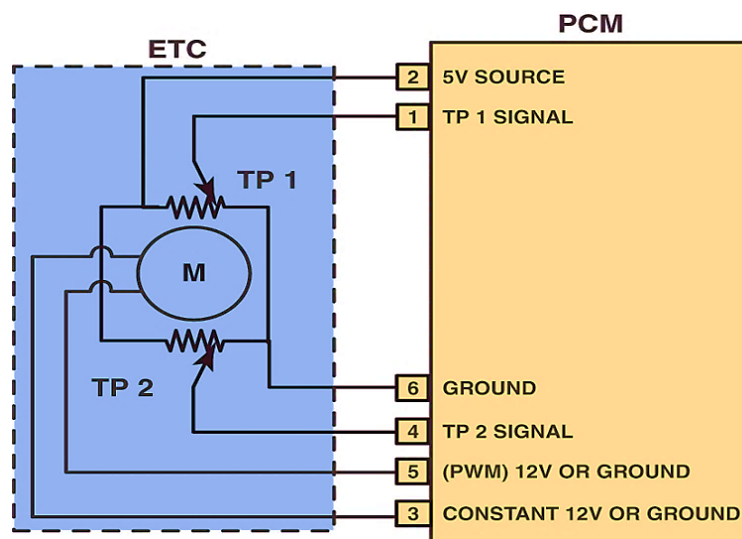

Schematic of a typical electronic throttle control (ETC)

Terminal 5 is always a PWM signal and Terminal 3 is always constant. Both power and ground are switched to change the direction of the motor.

Three-Wire Potentiometer TPS Sensors use 5-volt reference from the Powertrain Control Module (PCM) and produce an analog (variable) voltage signal proportional to throttle plate position. The sensors produce opposite signals relative to throttle movement. One sensor starts at low voltage (about 0.5V) and increases as throttle plate opens. The other sensor starts at higher voltage (about 4.5V) and produces lower voltage as the throttle plate open. The total voltage of both combined at any throttle plate position is 5 volts

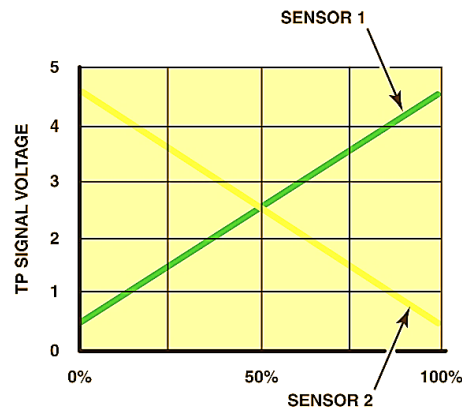

Why Not Use a Stepper Motor for ETC?

A stepper motor is a type of motor that has multiple windings and is pulsed by a module to rotate a certain number of degrees when pulsed. The disadvantage is that a stepper motor is too slow to react compared with a conventional DC electric motor and is the reason a stepper motor is not used in electronic throttle control systems.

- **Fault Mode**
 - Due to redundant sensors, many faults result in “limp home” situation instead of total failure
 - Indicates following actions performed by PCM:
 - Engine speed limited to default speed (1200–1600 RPM)
 - Slow or no response when accelerator pedal depressed
 - The cruise control system is disabled
 - DTC set

- **Limp-in Mode**
 - ETC may enter limp-in mode if any of following occurs:
 - Low battery voltage detected
 - PCM failure
 - One TPS and MAP sensor fail
 - Both TPS sensors fail
 - ETC actuator motor fails
 - ETC throttle spring fails

- **Vacuum Leaks**
 - ETC system compensates for many vacuum leaks.
 - ETC system moves throttle as needed to achieve proper idle speed.

- **ETC-Related Performance Issues**
 - Throttle body may need cleaning if:
 - Lower than normal idle speed
 - Rough idle
 - Engine stalls when coming to a stop (coast-down stall)

- **Diagnostic Procedure**
 - Verify customer concern
 - Use scan tool to check for DTCs
 - If stored DTCs, follow service information instructions to diagnose.
 - If no stored DTCs, check scan tool data for possible fault areas in system.

- **Scan Tool Data**
 - APP indicated angle
 - Scan tool displays 0%–100%
 - When throttle released, indicated angle should be 0%
 - When throttle depressed to wide open: 100%
 - TPS desired angle
 - Scan tool displays 0%–100%
 - Represents desired throttle angle as commanded by driver
 - TPS indicated angle
 - Angle of measured throttle opening
 - Should agree with TPS desired angle
 - TPS sensors 1 and 2
 - Scan tool displays “agree” or “disagree”
 - If PCM or throttle actuator control (TAC) module receives signal from one TPS sensor not in proper relationship to other TPS sensor, scan tool will display “disagree”

On some vehicles, the operation of the ETC can be tested using a scan tool. Use the “throttle follower test” procedure on the scan tool. An assistant must check that the throttle plate is moving as the accelerator pedal is depressed.

Throttle Body Cleaning Procedure

- Be sure ignition key is out of vehicle and ready light is off
- Remove air inlet hose from throttle body
- Spray throttle body cleaner onto shop cloth
- Open throttle body; use shop cloth to remove varnish and carbon deposits from housing and plate
- Reinstall inlet hose being sure no air leaks between hose and assembly
- Start engine and allow PCM to learn correct idle
 - If idle incorrect, check service information to perform throttle relearn.

Throttle Body Relearn Procedure

- Before performing relearn, meet following conditions:
 - Accelerator pedal released
 - Battery voltage higher than 8 volt
 - Vehicle speed zero
 - Coolant temperature higher than 40°F (5°C) and lower than 212°F (100°C)
 - Intake air temperature higher than 40°F (5°C)
 - No throttle DTCs
 - Turn ignition on (engine off) for 30 seconds
 - Turn ignition off and wait 30 seconds
 - Start engine; idle learn procedure should cause engine to idle at correct speed

Review Questions

- | | |
|--|---|
| <p>1. The two chambers added to an air/fuel sensor are known as?</p> <ul style="list-style-type: none">a. Air Reference and Diffusion Chamberb. Pump cell and air referencec. Air reference and signald. Signal and Pump <p>2. Technician A states that speed density systems can continuously calculate BARO. Technician B states that speed density systems take a BARO reading at KOEO. Who is correct?</p> <ul style="list-style-type: none">a. Technician Ab. Technician Bc. Both Technicians A and Ba. Neither Technician A nor <p>3. Technician A states that the PCM uses the Knock sensor signal to control spark knock. Technician B states that Knock Sensors are piezoelectric. Who is correct?</p> <ul style="list-style-type: none">d. Technician Ae. Technician Bf. Both Technicians A and Bg. Neither Technician A nor B <p>4. A circuit where the PCM supplies the power, and the switch supplies the ground is known as a:</p> <ul style="list-style-type: none">a. Pull-up circuitb. Pull-down circuitc. Solenoid control circuitd. None of the above <p>5. Which type of Mass Airflow Sensor (MAF) uses a burn-off circuit?</p> <ul style="list-style-type: none">a. Hot wireb. Hot filmc. Vane airflowd. Karmen-Vortex | <p>6. Technician A states that to perform a throttle body relearn procedure, voltage should be no less than 8V. Technician B states that the relearn procedure requires full battery voltage. Who is correct?</p> <ul style="list-style-type: none">a. Technician Ab. Technician Bc. Both Technicians A and Bd. Neither Technician A nor B <p>7. When the PCM grounds an injector, the voltage drop should be close to:</p> <ul style="list-style-type: none">a. 12 voltsb. 14 voltsc. 0 voltsd. 5 VRef <p>8. Technician A states that Vehicle Speed Sensors are Hall-effect switches. Technician B states that Vehicle Speed Sensors are of the permanent magnet type. Who is correct?</p> <ul style="list-style-type: none">a. Technician Ab. Technician Bc. Both Technicians A and Bd. Neither Technician A nor B <p>9. Technician A states that the best way to check the performance of an air/fuel sensor is with a scan tool. Technician B states the results of the PCM tests on the air/fuel sensors can be found in Mode 6. Who is correct?</p> <ul style="list-style-type: none">h. Technician Ai. Technician Bj. Both Technicians A and Bk. Neither Technician A nor B <p>10. ETC systems can compensate for vacuum leaks.</p> <ul style="list-style-type: none">a. Trueb. False |
|--|---|